

# SCREENINGS



The Publication of the **BC Stone, Sand & Gravel Association**

**WINTER 2024**

# A CHANGE IN SEASONS

STOCK PHOTO BY VECTEEZY



BCSSGA Mission Statement.....	2	Workplace Health and Safety	
Executive Board 2024-2025.....	2	Innovation Award .....	4
Elected Board Of Directors .....	2	GAIN Conference Report .....	5
Standing BCSSGA Committees.....	2	Committee Updates.....	7
President's Message.....	3	Deputy Minister's Award .....	8
Membership.....	4	About the Association and	
Upcoming Events .....	4	Benefits of Membership .....	13
		BCSSGA Associate Member	
		Directory .....	14

Inside this Issue

**Aggregates Build BC** .....



# BCSSGA Mission Statement

**THE BRITISH COLUMBIA STONE SAND AND GRAVEL ASSOCIATION** is committed to affordable, sustainable development of BC’s aggregate resources, providing information to the public, ongoing input to the province, and maintaining government regulations while fostering positive constructive communications with aggregate industry members and mining related associations across Canada.

## Standing BCSSGA Committees

COMMITTEE NAME	CHAIR
Government Relations	Derek Holmes gr@gravelbc.ca
Safety Committee	Mark Ellett safety@gravelbc.ca
Sustainability Committee	Danielle Gutwillinger sustainability@gravelbc.ca
Sustainability Sub-Committee	Social Media social-media@gravelbc.ca

## Executive Board 2024-2025

**Rick Kovach: President** (Kode Contracting)

**Dani Miller: Past President** (Mainland Construction Materials)

**David Rogalsky: Vice President** (Woodbrook Aggregates)

**Barry McLean: Treasurer** (Osprey Equipment)

**Derek Holmes: Director** (ex-officio)

## Elected Board Of Directors

**Jeff Adams** (FuelEx Energy Ltd.)

**Barry Chalmers** (Island Crushing)

**Tyson Craiggs** (Terus Construction)

**Nikki Keith** (Wilson M. Beck Insurance Services)

**Rick Kovach** (Kode Contracting Ltd.)

**Barry McLean** (Osprey Equipment)

**Crissy Ram** (Frontline Machinery)

**Dani Miller** (Mainland Construction Materials)

**David Rogalsky** (Woodbrook Aggregates)

**Lance Dexter** (Lafarge)

**Markus Tschopp** (Heidelberg)

**Kurt Strachan** (Limestone Cowboys)





## President's Message

Happy Fall Everyone,

It has been a dynamic time in our province, marked by political and economic shifts that will undoubtedly influence our industry.

A provincial election, after some recounting in a few ridings, has resulted in a majority NDP government. While the NDP remains in office, changes within the government, including a cabinet shuffle, brings new faces and challenges. We now have a new ministry and Minister of Mining and Critical Minerals, the Honorable Jagrup Brar, who has been an MLA since 2004 but has no prior experience in this sector. Additionally, a new Deputy Minister, Nathaniel Amann-Blake, has been appointed, signaling a fresh start for this ministry.

When such changes occur, mandate letters from the Premier outline the new priorities for cabinet ministers. As an association, we are proactively working to engage with Minister Brar and Deputy Minister Amann-Blake to introduce our association, highlight our role in the industry, and offer our support. Building a successful relationship with the new leadership, as we had with the Honorable Josie Osborne, is a key focus for us moving forward.

On the economic front, the Bank of Canada's recent significant drop in interest rates is expected to boost private investor confidence. This is a positive signal for our industry, as increased investment translates to more demand for aggregates, contractors upgrading their equipment fleets, and sustained business for equipment companies.

We've also been making steady progress with our education initiative, although sometimes it feels like a slow journey. Derek and I recently completed the Ontario Stone, Sand, and Gravel Association's initial 4-hour safety program. In Ontario, it is mandatory for all new hires in the mining and aggregate sectors to complete and pass this course within 60 days of starting employment. We are excited to roll out a similar program here.

Looking ahead to 2025, we plan to introduce the Aggregates 101 and 201 courses. I had the opportunity to take both courses in Toronto this

past summer and can attest to the immense value they bring to our industry. These courses cover essential topics such as permitting, crushing, washing, blasting, and more—providing a comprehensive understanding of the disciplines that define our industry.



Lastly, as we approach the holiday season, I encourage everyone to mark December 5th on your calendars for our annual Christmas luncheon in Surrey. It's a wonderful opportunity to come together, celebrate our successes, and enjoy the camaraderie of our members.

Wishing you all a joyful Christmas season filled with time spent with family and friends.

**Rick Kovach, President,**  
**BC Stone Sand and Gravel Association**  
[president@gravelbc.ca](mailto:president@gravelbc.ca)

### HSE Mining Learning Summit

The Sheraton Vancouver Guildford Hotel, Surrey, BC  
December 10<sup>th</sup>-11<sup>th</sup>, 2024

REGISTER EARLY - LIMITED SEATS AVAILABLE

The Office of the Chief Inspector is proud to partner with HSE Global Series to bring this inaugural learning event to the mining industry in British Columbia.

Join us at the HSE Mining Learning Summit, dedicated to advancing workplace culture, health, and safety, critical to the BC mining industry. This conference is intended for strategic and operational leaders, including worker and management representatives of occupational health and safety committees, safety superintendents, and others representing mining operations and beyond.

This conference offers a unique opportunity to engage with industry experts and explore innovative solutions to the challenges of ensuring the well-being of the mining workforce. By attending, you will gain valuable insights, and contribute to the collective effort promoting a modern culture of safety in the BC mining industry.



Scan for more info and to register



Office of the Chief  
Inspector of Mines



FOR MORE INFORMATION AND TO REGISTER:  
[www.hseglobalseries.com/schedule/canada](http://www.hseglobalseries.com/schedule/canada)

# Workplace Health and Safety Innovation Award

**\$1000.00 in Esso Fuel Cards**



The Workplace Health, Safety & Innovation Award recognizes a workplace practice, policy, program, process, or tool which demonstrates improvements in the area of health and safety. This includes anything which could be considered proactive, unique, creative or forward thinking.

Please see our website [www.gravelbc.ca](http://www.gravelbc.ca) to nominate someone you know who is taking safety to the next level.

## Membership

*Welcome new BCSSGA Members so far in 2024:*

**PAZ Fuels**

**TNDC Tahltan Nation  
Development Corporation**

**Chapman Sand and Gravel**

**Skwlay Aggregates**

**Highland Precast Inc.**

**Canadian Equipment Finance  
CEF**

**Luff Conveying Performance**

**Owl Aggregates Ltd.**

**Lower Nicola Site Services**

**Princeton Ready Mix PRM**

**IRONBIRD**

**Dirt by Nektar**

**Lhoist**

**The Western Group**

**Keltic Canada Development**

**Iron Creek Industries**

## Upcoming Events

### Meetings

2024 Regional Meeting, Northview  
Golf Club, Surrey, B.C.

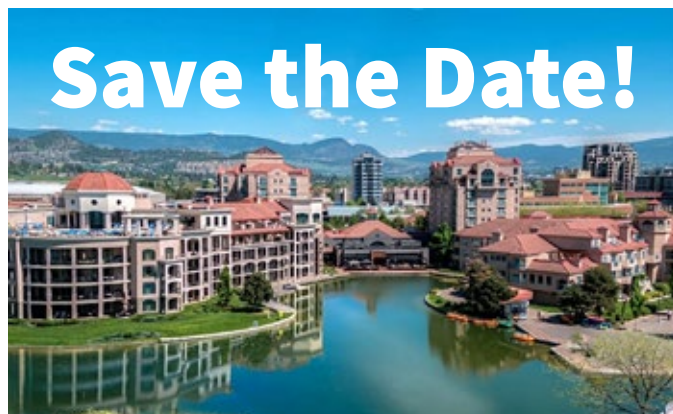

**April 2-3, 2025**

Conference, AGM and Trade Show,  
Delta Hotels Grand Okanagan Resort, Kelowna, B.C.



## GAIN Conference Report

On October 20-23<sup>rd</sup>, countries from around the globe united in Cordoba, Argentina for the 7th Global Aggregates Information Network (GAIN) conference. The GAIN meeting was held in conjunction with Argentina's National Aggregates Congress where local producers, mining associations and politicians converged on various industry topics which also included a trade show featuring new quarry equipment and technologies.

Held for the first time in South America, the conference welcomed an expanded delegation from Latin American countries with representatives from each Argentina, Brazil, Chile, Colombia and Costa Rica. Canada and the United States rounded out the Americas, while Aggregates Europe represented a conglomerate of 30 European countries. Asia recognized delegates from each China, Malaysia and South Korea, with New Zealand closing out the list of countries in attendance.



The Aggregate Producers Association of Canada (APAC) participated in the GAIN meeting, sharing industry initiatives from the various provinces along with current challenges such as access to resources,





a slowing economy, labour shortages, and the recent challenges faced with the rise in population due to record immigration levels.

The role of aggregates associations was evident throughout the meeting, particularly in convincing governments on the benefits of investing in infrastructure, and how essential aggregates are. Of note on this topic was the adding of aggregates to the Critical Minerals List in New Zealand, the first country to do so.

Sustainability was a key theme throughout the conference, with many countries presenting their plans on reducing carbon emissions, energy and water usage. Environmental Product Declarations (EPD's) were also discussed in length with countries at various stages of maturity level in terms of implementation and acceptance. Having adopted EPD's since a few years, Europe appears the most advanced, while they are growing in other parts of the world, most notably south of the border in the United States.

Significant developments in technology were presented by China while all countries presented great examples of public relations, communications and environmental stewardship. Labour shortages and the difficulties in attracting new talent to the construction industry in general are sentiments and challenges faced mutually around the globe.

As 2024 comes to a close, APAC is looking to host a face-to-face meeting with delegates from each of the Canadian provinces and the respective provincial associations in early 2025. APAC is a not-for-profit organization aimed to connect aggregate producers across the country in order to support a stronger, unified, national industry that is safe, sustainable and growing, through networking, advocacy and the sharing of best practices.

**Brent Morrey**  
**President, Aggregate Producers Association of Canada**



At Frontline Machinery, we understand the unique demands and challenges the industry faces. That is why we are consistently pushing the status-quo, innovating, and leading the market in change.

With Frontline, you can trust that our team will support your project beyond just delivering a machine but ensuring that you get the most from your equipment through world-class after-sales parts, service, and support.

CRUSHING SCREENING WASHING CONVEYING

[frontline-machinery.com](http://frontline-machinery.com)  
info@fl-machinery.com | 1-855-625-2009

## Committee Updates

### From the Social Media Sub-Committee:

This year, our committee has seen our social media initiative thrive, thanks to the strong foundation we established in the launch phase. Our presence on Instagram has become a key channel for new members discovering our association, contributing to an increase in membership!

Our digital platform now serves as a vibrant community hub, where members actively engage, share updates, and showcase their achievements. Much of our content relies on member submissions, and these contributions keep our social media presence both authentic and dynamic, allowing us to showcase the talents and successes across our industry.

While our platform is increasingly self-sustaining, we continue to encourage members to share their stories and insights with us. Member-driven content reinforces our goal of fostering a connected,

collaborative community and ensures our social media reflects the full scope of our members' contributions. We would love to see some behind-the-scenes action of your operations - from pit development, crushing, placement, reclamation and everything in between! Submissions can be sent in to us at [social-media@gravelbc.ca](mailto:social-media@gravelbc.ca)

Be sure to follow us on Instagram at [@aggregatesbc](https://www.instagram.com/aggregatesbc), and connect with us on LinkedIn and Facebook under **BC Stone, Sand and Gravel Association**. Your engagement—likes, comments, and shares—helps amplify our members' voices and keeps our community thriving.

We look forward to seeing how our social media presence will continue to grow as a resource for sharing knowledge, celebrating successes, and welcoming new members to our association.

**-Danielle and Crissy**

### From the Sustainability Committee:

Dear Members,

In our ongoing commitment to celebrating the impact of the aggregate industry, we are pleased to announce the opening of nominations for the Deputy Minister's Community Service Award. This recognition is not just about the integral role our industry plays in building an affordable and prosperous British Columbia, but also highlights the substantial contributions made to our communities.

**Award Overview:** The Deputy Minister's Community Service Award is a testament to the aggregate industry's commitment to community welfare. It acknowledges the dynamic role played by aggregate producers, beyond the provision of materials. Their involvement takes various forms, from volunteering labour and equipment for community projects to supporting local organizations.

**Eligibility Criteria:** Companies in the aggregates industry that have supplied at least one project in a BC community are eligible for this prestigious award. Applications can be submitted by aggregate producers, community members, or any individual wishing to recognize the significant contribution of an aggregate producer to a community.

**Application Process:** To be considered for this award, submit the following by March 1, 2025:

1. A completed application form (found at [www.gravelbc.ca/emli-award](http://www.gravelbc.ca/emli-award))
2. A letter (maximum two pages) describing the contribution made by the company and the benefits to the community
3. Supporting information such as citations, media releases, media coverage, links, photographs, and support and thank-you letters.

**Selection Criteria:** Applications will be evaluated based on qualitative assessments of two key criteria:

1. The benefits to the community
2. The contribution made by the Producer

Submit your application to:  
[\*\*sustainability@gravelbc.ca\*\*](mailto:sustainability@gravelbc.ca)

The award will be presented at the BCSSGA Conference and Trade Show, April 2nd and 3rd, 2025. It's an opportunity to shine a spotlight on the outstanding efforts of our members and showcase the positive impact made on the communities we serve.

## Deputy Minister's Award

B.C.'s aggregate industry plays an important role in building an affordable and prosperous British Columbia. However, aggregate producers play a much larger part in our communities than purely providing the necessary resources for the construction of homes, public infrastructure, and roads. Their contribution takes a variety of forms including volunteering labour and equipment for community projects and events and supporting local organizations.

The Deputy Minister's Community Service Award recognizes outstanding contributions to communities across the province.

Let us come together to recognize and celebrate the heart and soul of our industry—the dedication to building not just structures but thriving communities.

Sincerely,  
**Danielle Gutwillinger, Chair,**  
**BCSSGA Sustainability Committee**  
[\*\*sustainability@gravelbc.ca\*\*](mailto:sustainability@gravelbc.ca)



Information and nominations for awards can be emailed to [\*\*sustainability@gravelbc.ca\*\*](mailto:sustainability@gravelbc.ca).



## From the Government Relations Committee:

The Government Relations (GR) Committee is tasked with addressing the most pressing matters for membership with law-makers and regulators from the various levels of government. Our goal is to meet as often as necessary with representatives from government and advocate for both the industry and membership in terms of policy, legislation, strategic direction and mandates. While individual matters are not tackled directly, they often lead the committee in search of root causes and most of all development of solutions which we can work through with government. Our regional representatives play



Honourable Tamara Davidson  
Minister of Environment and  
Parks



Honourable Jagrup Brar  
Minister of Mining and Critical  
Minerals



Honourable Lana Popham  
Minister of Agriculture and  
Food



Honourable Randene Neill  
Minister Water, Land and  
Resource Stewardship

The full list of the Executive Council and Parliamentary Secretaries can be found here: <https://www2.gov.bc.ca/gov/content/governments/organizational-structure/cabinet/cabinet-ministers>

While mandate letter have not been issued at the time of publication, we can expect much the same in terms of initiatives from this government and the natural resource ministers such as: UNDRIP implementation throughout the Ministries, *Land Act* reform and *Mineral Tenure Act* reform. You can be assured that your committee will be in front of these Ministers as soon as possible to introduce the Association, vocalize the needs of the industry to them and listen to their plans for strengthening the sector. Stay tuned to the weekly email as we update

an important role on the committee as they bring forward news and emerging issues from across the province for review and consideration.

The NDP government was elected in October and after some judicial re-counts David Eby, as Premier, swore in Members of Cabinet on November 18, 2024. Many new faces to the natural resources industries in the province were given prominent roles in the new government along with re-branding certain Ministries. Here's a run-down of the key changes and positions for the aggregate industry:

the Membership on these and other government announcements.

The Ministry of Mines has been making efforts to increase transparency in the work they do and have recently launched two new websites for the public where applications can be viewed and commented on and another where compliance and enforcement inspections are publicly posted.

New Public Consultation website: [Public Engagement Portal](#)

Compliance and Enforcement website: <https://nrccd.gov.bc.ca/records>

As the site is developed we are told that Orders from inspections will be available publicly.

Other initiatives for the Committee this year and

going forward are to help the Ministry decrease permitting timelines by promoting a risk based approach, implementing hard triggers for when supplemental reports are required to a Notice of Work and allowing them to make decisions for other Ministries in certain circumstances. Big asks...but that's what we do!

The Committee has also asked that we get back in front of government face-to-face, like we used to do before Covid introduced a world of video chat. We saw a great deal of benefit when we used to do this and it will be good for us to get back doing this again;

### **From the Safety Committee: *Enhancing Safety Standards and Innovations for 2025***

As we look ahead to 2025, the BC Sand, Stone, and Gravel Association Safety Committee remains steadfast in its mission to elevate safety standards across the mining industry. This year, we prioritize worker orientation and training standards, ensuring that all employees, regardless of experience level, have the knowledge and tools necessary for safe and effective operations. Comprehensive mining focused training protocols will aim to mitigate risk, foster a proactive safety culture, and establish a strong baseline for workplace practices.

In tandem with this, we are advancing lone-worker safety initiatives. Our partnerships with industry leaders will drive investigations into innovative wearable technology solutions to enhance real-time safety monitoring and response capabilities. These initiatives reflect our commitment to leveraging emerging technologies to protect our most vulnerable workers.

We are also excited to highlight the value of the new silica exposure tool launched in 2024. This tool represents a significant leap forward in protecting workers from silica-related hazards, offering improved measurement, monitoring, and prevention capabilities. Throughout 2025, we will work diligently to provide educational resources and training to our industry partners, maximizing its impact

especially with so many new faces in Cabinet.

As always, this is your Association so we really do need to hear from you. What is your main concern and how can we as a Committee and Association work for you? Please feel free to email us and join in the conversation.

**Sincerely,**  
**Derek Holmes, Chair, BCSSGA Government  
Relations Committee**  
[gr@gravelbc.ca](mailto:gr@gravelbc.ca)

and ensuring widespread adoption.

Recognizing the power of collaboration and communication, we are focused on establishing communication tools and networking opportunities for safety professionals and regulatory bodies, fostering stronger connections and shared learning across the industry. Our efforts will include creating a comprehensive online resource library to support all employers working within our sector, providing easy access to critical information and best practices.

Additionally, we will begin holding quarterly safety meetings and publishing summaries online to encourage better collaboration and communication. By sharing insights and strategies through these meetings, we aim to continually empower companies to improve their safety programs and create safer workplaces.

We can continue building a safer, more resilient aggregate mining sector through collaboration, innovation, and education.

**Mark Ellett, Chair, BCSSGA Safety Committee**  
[safety@gravelbc.ca](mailto:safety@gravelbc.ca)





# OPS IQ

We know the challenge of downtime and maintenance breakdowns disrupting industrial operations impacts production and profitability. Ops IQ was designed as a machine intelligence solution crafted specifically to address your operation's unique challenges. Utilizing AI, we are delivering machine health insights and predictive maintenance issues before they impact your operation.

Using our 60 years of mechanical insights from maintaining the biggest machines on earth, Ops IQ's comprehensive monitoring and control solution was built from those insights and developed from working side-by-side with our customers and industry feedback.

It goes beyond simple equipment monitoring; Ops IQ deeply comprehends machine systems and is backed by our expert engineers and field service teams to support real-time decisions in the field. By working in tandem with operations teams, it facilitates accurate and real-time data to ensure a seamless connection between technology and operational excellence.

With Ops IQ, you gain timely access to critical data, empowering your operations to function efficiently and, above all, safely.



LEARN MORE

HYDRAULIC PRESSURE

CSS & LINEAR WEAR

OIL TEMPERATURE

FLOW & LEVELS

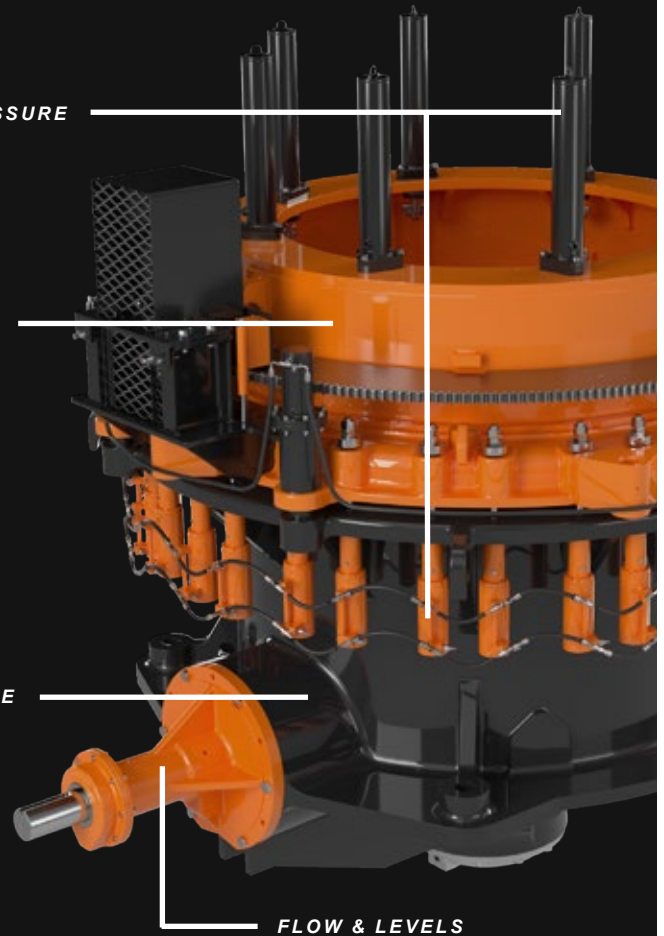



# CONFERENCE & TRADE SHOW

## British Columbia Stone, Sand and Gravel Association

**April 2-3, 2025 · Delta Hotels Grand Okanagan Resort, Kelowna, B.C.**

We are pleased to announce that the 2025 venue will be at the Delta Hotels Grand Okanagan Resort in the Kelowna, B.C.

We are looking forward to hosting you at this beautiful venue with expanded room for trade show booths, networking opportunities, and conference delegates. We look forward to seeing you all there.

### AGENDA AT A GLANCE:

#### Wednesday, April 2

- “CRUSH-OFF” Demo Day at Crawford Quarry
- Bowling at BNA Brewery
- Mixer Eat Meet & Greet
- Vendor Trade Show
- Live music

#### Thursday, April 3

- Breakfast & Lunch
- Learning Workshop
- Guest Speakers
- Annual General Meeting
- Vendor Trade Show
- Gala Dinner and Keynote Speaker, Tyler Hayden, CSP, BRM (OEE)

Visit the website to register NOW: [www.gravelbc.ca](http://www.gravelbc.ca)

Any questions, please contact: [victoria@gravelbc.ca](mailto:victoria@gravelbc.ca)  
(778-571-2670)





## About the Association and Benefits of Membership

The BC Stone Sand and Gravel Association (BCSSGA) is a professional Association that represents all of the Aggregate Producers in British Columbia. Our members are Aggregate Producers, Associates who work with and supply to Producers and we focus our efforts on issues that matter most to our members: government relations, sustainability and safety/training.

The aggregate industry is highly regulated with legislation and government policy developing quickly. Our strength is in our direct line of communication with the various levels of government who consult with our association whenever changes are considered in the Ministry of Energy, Mines and Low-Carbon Innovation (EMLI) affecting mining in the province. We also engage with local governments on behalf of our members to help municipalities understand the challenges our industry faces and lobby for regulations that work for Producers.

Sustainability is not a new concept in the BCSSGA but has been re-branded to reflect how we are perceived in public and push initiatives that build a grassroots knowledge of the value of aggregates in our schools. The Sustainability Committee also manages the Deputy Minister's award that recognizes outstanding community relations by aggregate producers in the Province.

Safety and training are foundations of the aggregate industry and the Association makes sure that we

inform our members about changes to the Health Safety and Reclamation Code for Mines in BC. We have a seat at the table of the Code Review Committee to ensure that the Code works for all mines in BC, not just the large metal mines which only account for a small number of overall provincial permits. The safety committee is also dedicated to providing resources for small operators to ensure their business has the latest and most up to date information available for their safety program.

Becoming a member in the Association ensures we have the numbers and resources to stay relevant with government and non-government entities. Producers benefit by having a strong industry voice advocating for them so they can stay focused on their business and regular updates and meetings to share and learn from others. We have government representatives attend and speak at every one of our meetings. Associates benefit from the networking opportunities and meetings hosted by the BCSSGA during the year with access to key decision makers in the organization and the ability to advertise their business.

For more information please contact  
[victoria@gravelbc.ca](mailto:victoria@gravelbc.ca)  
 or **778-571-2670**



# BCSSGA Associate Member Directory

<i>Company Name</i>	<i>Phone Number</i>	<i>Email / Website</i>
Alternative Belting	604-803-6445	<a href="mailto:tsmart@altbelt.com">tsmart@altbelt.com</a>
BIDADOO	604-3169191	<a href="mailto:blakem@bidadoo.com">blakem@bidadoo.com</a>
Brandt	604-882-8888	<a href="mailto:mladd@brandt.ca">mladd@brandt.ca</a>
Canadian Equipment Finance	778-738-1105	<a href="mailto:dustin.bosch@cefl.ca">dustin.bosch@cefl.ca</a>
Cassiar East- Yukon Expediting	604-926-8454	Geology, Geomorphology, Sedimentology (no website)
Diachem Polymers	604-789-2498	<a href="http://diachem.ca">diachem.ca</a>
Diamond Equipment Group	604-425-1400	<a href="http://Diamondequip.com">Diamondequip.com</a>
Dirt by Nektar	604-655-1731	<a href="mailto:todd.hagen@nektar.io">todd.hagen@nektar.io</a>
Dyno Nobel	1-800-473-2675	<a href="http://Dynonobel.com">Dynonobel.com</a>
Eco-Agg Concrete Recycling	604-613-9080	<a href="http://Recycleconcrete.ca">Recycleconcrete.ca</a>
Elrus Aggregate Systems	403-279-7741	<a href="mailto:gwheeliker@elrus.com">gwheeliker@elrus.com</a>
Finning (Canada)	1-888-346-6464	<a href="http://Finning.com">Finning.com</a>
Foreman Equipment	1-888-852-9021	<a href="http://foremanequipment.com">foremanequipment.com</a>
Frontline Machinery	1-855-625-2009	<a href="http://frontline-machinery.com">frontline-machinery.com</a>
FuelEx Energy Ltd.	604-563-3639	<a href="http://fuelenergy.ca">fuelenergy.ca</a>
Haver & Boecker Niagara	778-775-1515	<a href="mailto:mkopper@havercanada.com">mkopper@havercanada.com</a>
Hyland Precast Inc.	250-792-2045	<a href="mailto:mswift@hykandprecast.com">mswift@hykandprecast.com</a>
Holmes Mining Consultants Ltd.	604-309-3028	<a href="http://holmesmining.ca">holmesmining.ca</a>
Inland Truck and Equipment	1-250-613-1086	<a href="http://Inland-group.com">Inland-group.com</a>
Innovative Mining Services	1-844-556-7625	<a href="http://lms-group.ca">lms-group.ca</a>
Ironbird Contracting and Consult.	250-284-1102	<a href="mailto:cory.mcewan@ironbirdcc.com">cory.mcewan@ironbirdcc.com</a>
Iron Creek Industries	250-306-2099	<a href="mailto:dscott@ironcreekindustries.ca">dscott@ironcreekindustries.ca</a>
Keltic Canada Development	250-215-6161	<a href="mailto:liyongkun.ca@gmail.com">liyongkun.ca@gmail.com</a>
LHoist	778-773-1222	<a href="mailto:john.halliday@lhoist.com">john.halliday@lhoist.com</a>
LIEBHERR Canada Ltd.	604-270-3266	<a href="mailto:Todd.james@liebherr.com">Todd.james@liebherr.com</a>
Lonetrack Equipment	604-856-7278	<a href="http://lonetrack.com">lonetrack.com</a>
Lower Nicola Site Services	250-374-4551	<a href="mailto:bkelly@infracon.com">bkelly@infracon.com</a>
Luff Industries Ltd.	403-279-3555	<a href="mailto:stephanie@luffindustries.com">stephanie@luffindustries.com</a>
Machinery Supply	1-403-503-7877	<a href="http://machinerysupply.ca">machinerysupply.ca</a>
Metro Testing & Engineering	604-543-8871	<a href="http://metrotesting.ca">metrotesting.ca</a>
Mormak Equipment	1-250-542-7350	<a href="http://mormak.com">mormak.com</a>
Nors Construction Equipment	250-617-4760	<a href="mailto:dcoe@nors.com">dcoe@nors.com</a>
PAZ Fuels	604-857-5711	<a href="mailto:justin@pazfuels.com">justin@pazfuels.com</a>
Pro Track	604-396-1120	<a href="mailto:mike@protrackbc.com">mike@protrackbc.com</a>
Ritchie Bros Auctioneers	778-331-5000	<a href="http://Rbauction.com">Rbauction.com</a>
Ritchie Bros Financial Services	778-331-9168	<a href="mailto:cmccrum@rbfinance.com">cmccrum@rbfinance.com</a>
SkreenQuip Sales and Rentals	604-940-8210	-



Company Name	Phone Number	Email / Website
SLR Consulting (Canada)	604-738-2500	<a href="http://slrconsulting.com">slrconsulting.com</a>
SMS Equipment	604-888-9700	<a href="http://smsequipment.com">smsequipment.com</a>
Star West Petroleum	604-941-7676	<a href="http://swpetroleum.ca">swpetroleum.ca</a>
Summit Trailer	1-250-492-5445	<a href="http://summittrailer.ca">summittrailer.ca</a>
Thurber Engineering	604-684-4384	<a href="mailto:info@thurber.ca">info@thurber.ca</a>
UNICAST	250-317-3803	<a href="mailto:kris@unicast.ca">kris@unicast.ca</a>
Western Canadian Screens	604-520-3073	<a href="mailto:gregn@thewesterngroup.com">gregn@thewesterngroup.com</a>
Westerra Equipment	778-369-2013	<a href="http://westerraequipment.com">westerraequipment.com</a>
Westrek Geotechnical Services	778-765-9525	<a href="http://westrekgeotech.com">westrekgeotech.com</a>
Wilson M. Beck Insurance	604-437-6200	<a href="http://wmbeck.com">wmbeck.com</a>

Please contact Victoria at [victoria@gravelbc.ca](mailto:victoria@gravelbc.ca) to update your information.

**CRUSH • SCREEN • WASH • RECYCLE**

1-888-852-9021 • [www.foremanequipment.com](http://www.foremanequipment.com)

**FOREMAN**  
EQUIPMENT LTD.

**POWERSCREEN**  
A TEREX BRAND

**EVOQUIP**  
A TEREX BRAND

**MDS**  
A TEREX BRAND

**TEREX**  
WASHING SYSTEMS

# BC Stone, Sand & Gravel Association

## MEMBERSHIP PACKAGE

The British Columbia Stone Sand and Gravel Association is the voice of the aggregate industry in BC. Since 1988, the Association has been actively representing the industry and its interests at all levels of government and in communities throughout BC.

### Member Benefits:

- Regular access to other membership to learn from, coordinate with, and improve industry performance and standards, while ensuring a reasonable regulatory environment is maintained by governments
- Effective representation at all levels in government to ensure decision makers from the local council to the cabinet chamber hear the voice of aggregate producers and understand our interests as an industry
- Regular engagement with the Executive and Board of Directors to make sure that membership's voice is heard and conveyed to government and regulatory decision makers
- The inside scoop on potential impacts to the industry, be that regulatory change, tax changes, or potential technological advances that can give you the edge in your business
- Access to the association's newsletter, *Screenings Magazine*, and the ability to contribute to the ongoing dialogue



### Government Relations

Legislative and regulatory issues impacting your business are faced on an ongoing basis. The BCSSGA represents the collective voice of BC's aggregate producers with all three levels of government. Get updates on regulatory issues facing the industry and your business and bring your concerns to the table. Harnessing our power in numbers, the BCSSGA is an effective conduit to for industry consultation and engagement with government agencies and representatives. This is your opportunity to help advance the industry's interests and competitiveness.

### Communications

BCSSGA's quarterly publication, *Screenings*, will be delivered to your inbox throughout the year with pertinent information about the aggregate industry, regulatory issues facing the industry, and updates on the Association's activities. Articles that appear in the newsletter could make a difference in your company's operations. BCSSGA also offers advertising opportunities to promote your company's goods and services to our industry focused distribution list.

BCSSGA Members also receive exclusive access to the **BCSSGA Weekly News Clipping service** which brings a round-up of industry news to your inbox every Friday. The Weekly News includes association updates and important news bulletins. Make sure you are in the know.



## FEES

The Association's annual fee structure is based on total annual production.

### Producer Members

Category	Tonnes	Fees / Year	GST	Total
#1	1 – 20,000	\$750	\$37.50	\$787.50
#2	20,001 – 50,000	\$1,000	\$50.00	\$1050.00
#3	50,001 – 100,000	\$1500	\$75.00	\$1575.00
#4	100,001 – 500,000	\$3000	\$150.00	\$3150.00
#5	500,001 – 2,000,000	\$4000	\$200.00	\$4200.00
#6	Over 2,000,000	\$7000	\$350.00	\$7350.00

### Associate Members

Category	Tonnes	Fees / Year	GST	Total
#7	No Production	\$1000	\$50	\$1050.00

GST #88975 9783 RT0001

We are pleased to be able to offer companies and individuals the opportunity to pay their annual membership fees, advertising fees and other gifts to the BCSSGA, using Visa or MasterCard.

Please make all cheques payable to:

**BC Stone, Sand & Gravel Association**  
**PO Box 1004**  
**Aldergrove, BC, V4W 2V1**

If paying by credit card, a credit card payment invoice will be sent to you via email.

Contact Victoria for any inquiries  
 victoria@gravelbc.ca  
 778-571-2670

# SCREENINGS



The Publication of the **BC Stone, Sand & Gravel Association**

## ADVERTISING MEDIA KIT

The **British Columbia Stone Sand and Gravel Association** is the voice of the aggregate industry in BC. Since 1988, the Association has been actively representing the sector and its interests at all levels of government and to stakeholders throughout BC. The industry itself is comprised of more than 2000 operators that employ 10,000 people and generate over 1 billion dollars of business while producing over 55 million tonnes of aggregate supply to every community in the province.

## WHY ADVERTISE?

Every BCSSGA member will receive quarterly editions of the Screenings magazine, each containing insightful editorial content and extensive exposure to a diverse audience. Additionally, the magazine is distributed at various events, including the annual BCSSGA Conference & AGM, giving advertisers prime exposure to members and event attendees.

Not only do we send all editions of Screenings directly to our exclusive subscribers, but we also archive them on our website. This ensures that our members and visitors can access past issues even after their publication date.

## SCREENINGS PROFILE



650+ circulation



150+ members

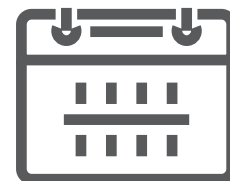

4 issues annually

Aggregates Build BC





## ADVERTISING RATES

SIZE	1 Edition	2 Editions	3 Editions	4 Editions
Full page	\$500	\$800	\$1,300	\$1,500
Half page	\$250	\$400	\$650	\$750
Third page	\$170	\$270	\$440	\$500
Quarter page	\$125	\$200	\$325	\$375

\*Rates per edition

## SPECIFICATIONS



**Full Page**  
7.75" wide x 9.5" tall



**Half Page**  
7.75" wide x 4.75" tall



**Third Page**  
7.75" wide x 3.125" tall



**Quarter Page**  
3.8125" wide x 4.6875" tall

Preferred format for digital files is a high resolution PDF file. We also accept Adobe InDesign and Adobe Illustrator files, however, all graphics and fonts must be included.

## INQUIRIES

Contact Victoria Holmes at 778.571.2670 or [Victoria@gravelbc.ca](mailto:Victoria@gravelbc.ca)



# BCSSGA

British Columbia **Stone Sand & Gravel Association**

BC stone, sand and gravel producers are helping build sustainable communities throughout the province.

**British Columbians use 10-15 tonnes of aggregate per person per year.**



1 km of highway  
**30,000 Tonnes**

Hospital **60,000 Tonnes**  
School **30-40,000 Tonnes**



1 km of railroad  
**16,000 Tonnes**

House  
**100-300 Tonnes**



**One truck carries 15 Tonnes of aggregate**